



BLX
LXT
100-110 36V

Makita

CONCRETE

2020/2021 REFERENCE GUIDE



CONCRETE REFERENCE GUIDE

REBAR TYING / REBAR CUTTING
PAGE 4

CONCRETE CUTTING / PREPARATION
PAGE 5

DEMOLITION
PAGE 6

DRILLING
PAGE 7 - 8

SURFACING / GRINDING / PERCUSSION
PAGE 9

CORDLESS
PAGE 10 - 11

TOOL COMPARISON
PAGE 12 - 13

DUST MANAGEMENT
PAGE 14 - 15



GET MORE DONE WITH FOUR LXT® BATTERIES

PDC01 NEW
LXT® and LXT® X2 (36V) Portable Backpack Power Supply

- Backpack utilizes four Lithium-Ion batteries to provide longer run time for LXT® and LXT® X2 (36V) tools
- Provides up to 4X the run time when used with Makita LXT® 18V products
- Provides up to 2X the run time when used with Makita LXT® 18V X2 (36V) products
- Includes 18V X2 (36V) adapter (191A52-9)
- Connector cord compatible with 18V adapter or 18V X2 (36V) adapter (18V adapter 191A53-7 sold separately)
- Adjustable ergonomic harness for operator comfort



CONVENIENCE

Backpack utilizes four Lithium-Ion batteries to provide longer run time for LXT® and LXT® X2 tools



DESIGN

L.E.D. battery charge indicator allows monitoring of charge on all four batteries individually



COMFORT

Wide padded adjustable straps and hip belt



COMPATIBILITY

Connector cord compatible with 18V adapter or 18V X2 (36V) adapter

Compatible machine or tool category:

Cordless chain saw, cordless pole saw, cordless blower, cordless grass trimmer, cordless string trimmer, cordless multi-function power head, cordless hedge trimmer, cordless grass shear, cordless pole hedge trimmer, cordless angle grinder, cordless rotary hammer (except XRH08/XRH10/XRH11). The compatible category of tool or machine is subject to change without notice. Refer to the latest instruction manual for the information on the compatible category of tool or machine.

WARNING: Never use this unit with tools or machines categorized below.

Using this unit with non-compatible tools or machines may cause personal injury or malfunction. Cordless garden sprayer, battery powered pruning shears, battery powered wheelbarrow, motor-assisted bicycle, cordless backpack vacuum cleaner, robotic cleaner, cordless fan jacket, cordless heated jacket

6.0Ah
BATTERY



BL1860B
18V LXT® 6.0Ah
Lithium-Ion Battery
BL1860B-2
(2-Pack)

5.0Ah
BATTERY



BL1850B
18V LXT® 5.0Ah
Lithium-Ion Battery
BL1850B-2
(2-Pack)

2.0Ah
BATTERY



BL1820B
18V LXT® Compact 2.0Ah
Lithium-Ion Battery
BL1820B-2
(2-Pack)



DC18RD

18V Dual Port Rapid Optimum Charger

- Charges two batteries at the same time

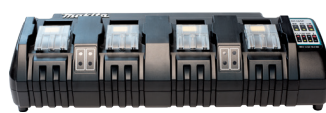

DC18SF

18V Dual Port Rapid Optimum Charger

- Will accommodate up to four Makita® 18V Lithium-Ion batteries



DC18E

18V Optimum Automotive Charger

- Charge 18V LXT® batteries in your auto or truck

INCREASE PRODUCTIVITY ■ ELIMINATE CORDS ■ REDUCE EXCESSIVE NOISE



DISCOVER THE CONVENIENCE OF WIRELESS AUTO-START

Makita's Auto-Start Wireless System (AWS™) uses Bluetooth® technology for wireless power-on and power-off communication between the equipped tool and dust extractor. Once connected via AWS™, your dust extractor will automatically power on or off when your cordless tool starts or stops, running only when your cordless tool is in use.*

LEARN MORE
[MAKITATOOLS.COM/AWS](https://www.makitatools.com/aws)

*Available on select models



MAXIMUM PERFORMANCE NO CORDS NEEDED

Unplug the cord and pick up Makita's 18v LXT® X2 tools. Powered by two LXT® batteries, X2 offers more power, speed and run-time without the hassles of a cord. Like all of our other LXT® tools, our X2 lineup is fully compatible with all LXT® batteries and chargers. Tough out bigger jobs with X2 tools and go back to work with any of our 225+ LXT® solutions.



LEARN MORE
[MAKITATOOLS.COM/LTXX2](https://www.makitatools.com/ltxx2)

*225+ solutions in 2020. Tools shown with optional accessories



MM4® 4-STROKE ENGINE

NO MORE OIL MIXING

Engine seizure due to improper fuel and oil mixing is one of the most common failures of 2-stroke power equipment. Makita has a solution with efficient MM4® 4-stroke engine power equipment. Makita MM4® means no more fuel mixing for simplified operation and no need for a separate mixed oil-fuel can. In addition, Makita MM4® 4-stroke engines are engineered for lower noise, improved fuel economy, reduced exhaust, and faster, easier starts for increased efficiency. MM4® 4-stroke engines can be found in concrete power cutters as well as blowers, hedge trimmers, string trimmers, pole pruners, and more.



TRANSPARENT WIRE REEL COVER PROTECTS THE FEEDING MECHANISM FROM DEBRIS

DIGITAL ADJUSTMENT OF TYING STRENGTH TO MATCH VARIOUS TENSION STRENGTH REQUIREMENTS

WIRE REEL EASY-LOAD DESIGN WITH AUTOMATIC LOCKING MECHANISM BUILT INTO PROTECTIVE COVER

UP TO **5,300 TIES** USING AN 18V LXT® 5.0Ah BATTERY

TIES UP TO TWO #5 DIAMETER BARS OR FOUR #4 DIAMETER BARS IN UNDER 1 SECOND

2-MODES DELIVER SINGLE OR CONTINUOUS WIRE TIE ACTUATION



LXT BRUSHLESS

XRT01TK / XRT01ZK (TOOL ONLY)
18V LXT® Brushless Rebar Tying Kit

- Fast and seamless wire reel easy-load design with automatic locking mechanism built into protective cover
- Adjustable tying strength to match various tension strength requirements



199137-9
Steel Tie Wire, 21 Gauge

- Delivers up to 120 ties of #3 x #3 rebar per wire reel allowing for maximum productivity

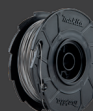

191L22-4
USA Made Steel Tie Wire, 21 Ga, 50/pk

- 21 gauge diameter black annealed steel wire for maximum strength



191A57-9
Electro Galvanized Tie Wire, 21 Gauge, 50/pk

- Up to 120 ties per wire reel allowing for maximum productivity

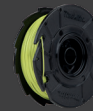

191J59-9
Poly-Coated Tie Wire, 21 Gauge, 50/pk

- 21 gauge diameter wire for maximum strength



LXT BRUSHLESS

5.0Ah BATTERY

7
GRADE TOOL AVAILABLE

XCS04Z

XCS04T1

18V LXT® Brushless Rebar Cutter Kit

- Performs up to 233 cuts of #5 rebar with one 18V LXT® 5.0Ah Battery
- Cutting capacity range of 1/8" - 5/8"
- Spark free cutting of rebar and steel rod



LXT BRUSHLESS

5.0Ah BATTERY

AUTOMATIC SPEED CHANGE

7
GRADE TOOL AVAILABLE

XCS04Z

XSC04T

18V LXT® Brushless™ 5-7/8" Metal Cutting Saw Kit, w/ Electric Brake and Chip Collector

- Powerful BL™ Brushless Motor Delivers up to 125 cuts per charge in 1" SCH 40 Pipe using an 18V LXT® 5.0Ah Battery
- Up to 2-1/4" cutting depth in various metal materials including thread rod, channel strut, conduit, pipe, square tubing, sheet metal and more



LXT

5.0Ah BATTERY

7
GRADE TOOL AVAILABLE

XCS01Z

XCS01T1

18V LXT® Rebar Cutter Kit

- Cutting capacity range of 1/8" - 3/4"; cuts up to 60 grade #6 rebar
- 4-way rotatable cutting blade makes up to 4,000 cuts of #3 (3/8") rebar before needing to be replaced
- Cutting head rotates 360° for different cutting positions



LXT BRUSHLESS

5.0Ah BATTERY

AUTOMATIC SPEED CHANGE

7
GRADE TOOL AVAILABLE

XCS06ZK

XCS06T1

18V LXT® Brushless Steel Rod Flush-Cutter Kit

- Effortless cutting of up to #8 rebar or 1" threaded rod; cuts up to an 1/8" flush to the surface
- Carbide-tipped blade delivers clean burr-free cutting with minimal spark emission



LXT

5.0Ah BATTERY

7
GRADE TOOL AVAILABLE

XRV01Z & XRV02Z

XRV01T(4')
XRV02T(8')

18V LXT® Concrete Vibrator Kits

- Dual directional switch to conveniently hold the tool in either horizontal or vertical positions
- Protective cover helps prevent battery contamination
- Makita-built motor delivers 13,000 VPM to help increase strength of concrete



LXT[®] BRUSHLESS REDESIGNED

XEC01PT1
18V X2 (36V) LXT[®] Brushless 9" Power Cutter Kit, w/ 4 Batteries (5.0Ah)

- Eliminates the hassles of gas with lower weight, reduced maintenance, and zero emissions allowing use in indoor environments
- The BL™ Brushless Motor eliminates carbon brushes, enabling the BL™ Motor to run cooler and more efficiently for longer life; delivers 6,600 RPM
- Electric brake stops the wheel in 4 seconds or less allowing for faster re-positioning

E-02973
9" Ultra-Premium Plus Diamond Blade, Segmented, General Purpose

- 3D Pattern Diamond means each diamond is placed in an even 3 dimensional pattern for unparalleled performance in lifetime and speed

E-02515
9" Diamond Blade, Segmented, General Purpose

- Taller 13mm segments are designed for longer life and faster cutting
- Up to 4x longer life than competitive blades



EK8100
16" 81 cc Power Cutter

- 5.6 HP with powerful 81 cc engine
- Improved decompression valve and metering spring for precise fuel regulation
- Start capacitor with start support function stores electrical energy resulting in significantly less pull start force



EK7651H
14" 76 cc MM4[®] 4-Stroke Power Cutter

- No oil mixing simplifies operation and prevents piston seizure due to improper mixing
- Eliminates the need for separate mixed oil/fuel can



EK7301
14" 73 cc Power Cutter

- 5.1 HP with powerful 73 cc engine
- Improved decompression valve and metering spring for precise fuel regulation



EK6101
14" 61 cc Power Cutter

- 4.4 HP with powerful 61 cc engine at only 19.6 lbs.
- Stratified Air Scavenging (SAS) recovers 75% of unburned fuel and reduces fuel consumption by 20%

SEGMENTED RIM DIAMOND BLADES

Diameter	Arbor	Material	Model	Part #
9"	1", 20mm	General Purpose	XAG13, XAG23, GA90405	A-95831
9"	1", 20mm	General Purpose		A-95847
14"	1", 20mm	Hard Materials	EK6101, EK7301, EK7651H	A-94627
14"	1", 20mm	General Purpose		A-94736
14"	1", 20mm	Dual Purpose		T-01270
16"	1", 20mm	General Purpose	EK8100	A-94742
16"	1", 20mm	Dual Purpose		T-01286

ULTRA-PREMIUM SEGMENTED DIAMOND BLADE

Diameter	Arbor	Material	Model	Part #
14"	1", 20mm	General Purpose	EK6101, EK7301, EK7651H	T-02537



DT4000
Power Cutter Dolly

- For use with Makita 4-stroke power cutters



DT2010
Power Cutter Dolly

- For use with Makita 2-cycle power cutters



988-394-610
2.6 Gallon Pressurized Water Tank

- Holds 2.6 gallons of pressurized water for wet cutting



4114
14" SJS™ Angle Cutter

- SJS™ technology is a mechanical clutch system that helps prevent motor and gear damage
- Built-in vacuum attachment port and rubber shield reduces dust and debris



4101RH
5" Masonry Saw

- Powerful 7.9 AMP motor for the most demanding jobs
- Special cover engineered to prevent water from entering into motor housing



4100KB
5" Dry Masonry Saw, with Dust Extraction

- Powerful 13 AMP motor delivers 12,200 RPM for the most demanding applications
- Transparent upper guard dust cover for increased visibility



GA5040X1
5" SJS™ II Angle Grinder with Tuck Point Guard

- Powerful 10.0 AMP motor delivers more output and 11,000 RPM
- Includes 5" dust extraction tuck point guard for clean and accurate tuck pointing and cutting

TUCK POINT BLADE



E-02680
4-1/2" Dual Sandwich Diamond Tuck Point Blade

- Taller 13mm segments are designed for longer life and faster cutting
- Dual sandwich design allows for faster and more efficient cuts

LXT[®] BRUSHLESS AFT[®] (BRAKE)



XAG13Z1
18V X2 LXT[®] (36V) Brushless 9" Cut-Off/Angle Grinder

- Electric brake stops the grinding or cut-off wheel in 4.5 seconds or less for maximum productivity
- Active Feedback-sensing Technology (AFT[®]) turns the motor off if rotation of the wheel is suddenly forced to stop

DUST EXTRACTION ATTACHMENT



198509-5
9" Dust Extraction Cutting Guard

- Fully Featured Sawing Guard for Precision Cutting and Maximum Dust Extraction
- For use with Makita XAG13Z and XAG23Z

HITS LIKE AIR WITHOUT THE VIBRATION

Vibration absorbing housing moves independently of the motor and hammer mechanism effectively isolating more vibration away from the user

Mechanical counterbalance system greatly reduces vibration and directs more impact energy to the work surface

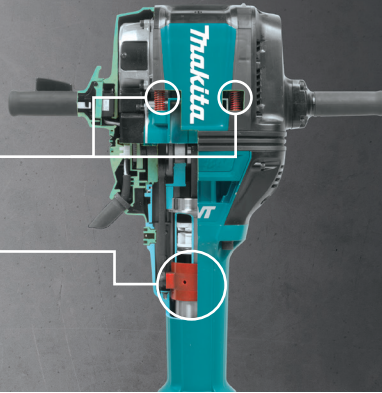

HM1812X3 70 lb. Advanced AVT® Breaker Hammer accepts 1-1/8" hex bits

- Hits like air without the vibration
- Efficient 15 AMP motor with improved hammer mechanism delivers 53.9 ft.lbs./72.8 joules of impact energy
- Advanced AVT® is a mechanical counterbalance, vibration absorbing housing and rubberized fixed handles designed to more effectively reduce vibration



Includes 4-piece steel set, premium cart and hex wrench



HM1810X3 70 lb. AVT® Breaker Hammer accepts 1-1/8" Hex bits

- Anti-Vibration Technology for 2X Less Vibration
- Efficient 15 AMP motor with improved hammer mechanism delivers 46.5 ft.lbs. of impact energy
- Anti-Vibration Technology is an internal counterbalance system that greatly reduces vibration



HM1317CB 42 lb. AVT® Demolition Hammer accepts 1-1/8" Hex bits

- Powerful 14 AMP motor delivers 25.7 ft.lbs. of impact energy to handle the most demanding applications
- Anti-Vibration Technology is an internal counterbalance system that greatly reduces vibration
- Variable speed control dial enables user to match the speed to the application for greater versatility

DUST EXTRACTION ATTACHMENT



197172-1 Dust Extraction Attachment, SDS-MAX, Demolition

- Use with HM1307CB, HM1317CB, and HM1812X3



HM1214C 27 lb. AVT® Demolition Hammer accepts SDS-MAX bits

- Powerful 14 AMP motor delivers 19 ft.lbs. of impact energy to handle the most demanding applications
- Soft start suppresses start-up reaction for more precision and better accuracy



HM1213C **NEW** 20 lb. AVT® Demolition Hammer accepts SDS-MAX bits

- Powerful 14 AMP motor delivers 18.8 ft.lbs. of impact energy to handle the most demanding applications
- Anti-Vibration Technology is an internal counterbalance system that greatly reduces vibration



HM1111C 17 lb. AVT® Demolition Hammer accepts SDS-MAX bits

- Powerful 14 AMP motor delivers 12.7 ft.lbs. of impact energy to handle the most demanding applications
- Anti-Vibration Technology is an internal counterbalance system that greatly reduces vibration



HM0871C **NEW** 12 lb. AVT® Demolition Hammer accepts SDS-MAX bits

- Powerful 10 AMP motor delivers 8.5 ft.lbs. of impact energy to handle the most demanding applications
- Anti-Vibration Technology is an internal counterbalance system that greatly reduces vibration

DUST EXTRACTION ATTACHMENT



196571-4 Dust Extraction Attachment, 1-1/8", Demolition

- Use with HR1111C, HM0870C, HM1203C, and HM1214C

DEMOLITION HAMMER STEEL		1-1/8"		3/4" Hex		SDS-MAX		Spline or 3/4" Hex - 21/32" Round		SDS-PLUS	
Description	Diameter	Part #	Diameter	Part #	Diameter	Part #	Diameter	Part #	Diameter	Part #	
Bull Point Demolition applications and starts holes in concrete	20-1/2" 16"	D-21353* B-45559	12" 18"	751421-A 751422-A	12" 18"	751423-A 751424-A	12" 18"	D-20074 D-19196	10"	D-51144	
Flat Chisel General purpose chipping, edging and channelling	(Self- Sharpening) 20-1/2"	D-21369*	1" x 12" 1" x 18"	751224-A 751225-A	1" x 12" 1" x 18"	751228-A 751231-A	1" x 12" 1-1/8" x 18" 2" x 12"	D-20080 D-19205 751234-A	3/4" x 10"	D-51150	
Scaling Chisel Wide chisel with two cutting angles for chipping dried concrete	3" x 20-1/2"	D-21347*	3" x 12"	751226-A	1" x 12" 2" x 12" 3" x 12"	751235-A 751229-A 751230-A	2" x 12" 3" x 12"	D-51172 751233-A	2" x 8-1/2"	D-51166	
Floor Scraper Cleanly Removes Tile, Linoleum and Flooring Adhesive	—	—	—	—	—	—	—	—	4" wide	A-68161	
One Piece Bushing Tool Removes excess concrete and roughens surface	1-3/4" x 14-3/4"	751717-A	1-3/4" x 9-3/4"	751714-A	1-3/4" x 10"	751715-A	1-3/4" x 10"	798144-5	—	—	
Asphalt Cutter Cuts asphalt or hard ground (not for use in concrete)	5" x 17-1/2"	751620-A	5" x 15"	751624-A	5" x 15"	751625-A	—	—	—	—	
Clay Spade Digs clay, shale, hard packed gravel and dirt	5-1/2" x 20"	751622-A	4-1/2" x 17"	751623-A	4-1/2" x 17"	751626-A	4-1/2" x 17"	798148-7	—	—	
Ground Rod Driver Drives ground rods into the ground	1" I.D. x 2-1/4" x 16"	751102-A	3/4" I.D. x 2-3/4" x 10"	751105-A	3/4" I.D. x 2-3/4" x 10"	751108-A	3/4" I.D. x 2-3/4" x 10"	751109-A	—	—	

*Also fits Air Tools



HR5212C
2" Advanced AVT® Rotary Hammer
accepts SDS-MAX bits

- Powerful 15 AMP motor delivers 14 ft.lbs. / 19 J. of impact energy to handle the most demanding applications
- Advanced AVT® is an air actuated counterbalance, vibration absorbing housing and impact bolt damper spring that more effectively reduces vibration
- Electronic Controller is a feature package that provides constant speed control, soft start, soft no-load and variable speed



HR4013C
1-9/16" Advanced AVT® Rotary Hammer
accepts SDS-MAX bits

- Powerful 11 AMP motor delivers 8.4 ft.lbs. / 11.4 J. of impact energy to handle the most demanding applications
- Advanced AVT® is an air actuated counterbalance, vibration absorbing housing and impact bolt damper spring that more effectively reduces vibration
- Torque limiting clutch engineered to prevent gear damage by automatically disengaging gears if the bit binds



XRH07PTUN **NEW**
18V X2 LXT® (36V) Brushless 1-9/16"
Advanced AVT® Rotary Hammer Kit
accepts SDS-MAX bits

- Two 18V LXT® Lithium-Ion batteries deliver the power and run time for corded demands without leaving the 18V LXT® platform
- Powerful BL™ Brushless motor delivers 250-500 RPM, 1,450-2,900 BPM and 8.4 ft.lbs. of impact energy to handle the most demanding applications
- Auto-start Wireless System (AWS™) utilizes Bluetooth® technology for wireless power-on/off communication between tool and dust extractor

DUST EXTRACTION ATTACHMENT



196537-4
Dust Extraction Attachment,
SDS-MAX, Drilling and Demolition
• Use with HR4013C/XRH07

196858-4
Dust Extraction Attachment,
SDS-MAX, Drilling and Demolition
• Use with HR5212C



HR4510C
1-3/4" AVT® Rotary Hammer
accepts SDS-MAX bits

- Powerful 13.5 AMP motor delivers 9.2 ft.lbs. of impact energy
- Anti-Vibration Technology is an internal counterbalance system that greatly reduces vibration
- Constant speed control automatically applies additional power to the motor to maintain speed under load



HR4002
1-9/16" Rotary Hammer
accepts SDS-MAX bits

- Powerful 10 AMP motor delivers 4.6 ft.lbs. of impact energy
- 2-mode operation for "Hammering Only" or "Hammering with Rotation"
- Torque limiting clutch engineered to prevent gear damage by automatically disengaging gears if the bit binds



HR4041C
1-9/16" Rotary Hammer
accepts SPLINE bits

- Powerful 12 AMP motor delivers 6.8 ft.lbs. of impact energy
- Constant speed control automatically applies additional power to the motor to maintain speed under load
- Torque limiting clutch engineered to prevent gear damage by automatically disengaging gears

DUST EXTRACTION ATTACHMENT



196074-8
Dust Extraction Attachment,
SDS-MAX, Drilling and Demolition
• Use with HR4002 and HR4510C



HR2811F
1-1/8" Rotary Hammer
accepts SDS-PLUS bits

- Powerful 7.0 AMP motor delivers 2.1 ft.lbs. of impact energy
- L.E.D. light illuminates drilling surface for more productivity in low light applications
- 3-mode operation for "Rotation Only", "Hammering with Rotation" or "Hammering Only"



HR2641
1" AVT® Rotary Hammer
accepts SDS-PLUS bits

- Powerful 8 AMP motor delivers 2.1 ft.lbs. of impact energy
- Anti-Vibration Technology (AVT®) is an internal counterbalance system that greatly reduces vibration
- Torque limiting clutch engineered to prevent gear damage



HR2661
1" AVT® Rotary Hammer w/ HEPA Dust Extractor
accepts SDS-PLUS bits

- Powerful 8 AMP motor delivers 1.6 ft.lbs./2.2 J. of impact energy to handle the most demanding applications
- Anti-Vibration Technology (AVT®) is an internal counterbalance system that greatly reduces vibration
- The built-on dust extractor captures concrete dust during drilling and is activated by the tool for operator convenience



DUST EXTRACTION ATTACHMENT



193472-7
Dust Extraction Attachment,
SDS-Plus, Drilling
• Use with HR2641, HR2811F, HR2475,
and HR2631F



195173-3
Dust Extraction Cup
• Use with XRH01, HR2641 & HR2631F



ROTARY HAMMER CARBIDE

PRECISION
Engineered to Drill More Accurate Holes

SPEED
Designed for Faster Material Removal

DURABILITY
Resist Flexing for Longer Life

Full Line Available in **SDS-MAX, SDS-PLUS, and Spline**

DUST EXTRACTOR

EXCLUSIVE
6 CUTTER

3 CUTTER

2 CUTTER



6-CUTTER HEAD

- 6 Cutting Edges engineered for drilling in reinforced concrete and more accurate holes
- Longer life, less vibration, and faster than competitive 4-cutter carbide bits

SDS-MAX ROTARY HAMMER CARBIDE BITS

Diameter/Length	Cutters	Part #	Diameter/Length	Cutters	Part #	Diameter/Length	Cutters	Part #	Diameter/Length	Cutters	Part #
1/2" x 13"	2	B-61307	11/16" x 21"	6	B-61379	7/8" x 36"	6	B-61444	1-1/4" x 13"	6	B-61519
1/2" x 21"	2	B-61313	3/4" x 13"	6	B-61385	1" x 13"	6	B-61450	1-1/4" x 21"	6	B-61525
9/16" X 13"	2	B-61329	3/4" x 21"	6	B-61391	1" x 21"	6	B-61466	1-1/4" x 36"	6	B-61531
9/16" X 21"	2	B-61335	3/4" x 36"	6	B-61400	1" x 36"	6	B-61472	1-3/8" x 21"	6	B-61547
5/8" x 13"	6	B-61341	13/16" x 21"	6	B-61416	1-1/8" x 13"	6	B-61488	1-3/8" x 36"	6	B-61553
5/8" x 21"	6	B-61357	7/8" x 13"	6	B-61422	1-1/8" x 21"	6	B-61494	1-1/2" x 21"	6	B-61569
5/8" x 36"	6	B-61363	7/8" x 21"	6	B-61438	1-1/8" x 36"	6	B-61503	1-1/2" x 36"	6	B-61575



3-CUTTER HEAD

- (3) 135° Cutting Edges offer the most efficient drilling without cracking the concrete around it
- Self-centering tungsten carbide tip features a more aggressive design for faster and more reliable hole starting
- Plows through rebar

SDS-PLUS 3-CUTTER ROTARY HAMMER CARBIDE BITS

Diameter/Length	Part # (1/Pk)	Part # (10/Pk)	Diameter/Length	Part # (1/Pk)	Part # (10/Pk)	Diameter/Length	Part # (1/Pk)	Part # (10/Pk)
3/16" x 4"	B-60975	B-61173	5/16" x 6"	B-61058	B-61248	5/8" x 10"	B-61139	-
3/16" x 6"	B-60981	B-61189	5/16" x 12"	B-61064	-	5/8" x 18"	B-61145	-
3/16" x 8"	B-60997	B-61195	3/8" x 6"	B-61070	B-61254	3/4" x 10"	B-61151	-
3/16" x 12"	B-61008	-	3/8" x 12"	B-61086	B-61260	3/4" x 18"	B-61167	-
1/4" X 4"	B-61014	B-61204	3/8" x 18"	B-61092	-	B-61298 5 Pc. SDS-Plus Bit Set Includes: (1) 3/16" x 6", (1) 1/4" x 6", (1) 5/16" x 6", (1) 3/8" x 6", (1) 1/2" x 6" SDS-PLUS bits		
1/4" x 6"	B-61020	B-61210	1/2" x 6"	B-61101	B-61276			
1/4" x 8"	B-61036	B-61226	1/2" x 12"	B-61117	B-61282			
1/4" x 12"	B-61042	B-61232	1/2" x 18"	B-61123	-			



2-CUTTER HEAD

- 3 contact points on the bit head increase speed and chipping power
- Self-centering tungsten carbide tip features a more aggressive design for faster and more reliable hole starting

SDS-PLUS 2-CUTTER ROTARY HAMMER CARBIDE BITS

Diameter/Length	Part # (1/Pk)	Part # (10/pk)	Diameter/Length	Part # (1/Pk)	Part # (10/pk)	Diameter/Length	Part # (1/Pk)	Part # (10/pk)	Diameter/Length	Part # (1/Pk)	Part # (10/pk)
5/32" x 6"	B-60551	B-60850	5/16" x 12"	B-60648	-	9/16" x 6"	B-60735	-	7/8" x 18"	B-60822	-
3/16" x 4"	B-60567	B-60866	3/8" x 6"	B-60654	B-60919	9/16" x 12"	B-60741	-	1" x 10"	B-60838	-
3/16" X 6"	B-60573	B-60872	3/8" x 12"	B-60660	B-60925	5/8" x 8"	B-60757	B-60953	1" x 18"	B-60844	-
3/16" X 12"	B-60589	-	3/8" x 18"	B-60676	-	5/8" x 12"	B-60763	-	B-60969 5 Pc. SDS-Plus Bit Set Includes: (1) 3/16" x 6", (1) 1/4" x 6", (1) 5/16" x 6", (1) 3/8" x 6", (1) 1/2" x 6" SDS-PLUS bits		
7/32" x 6"	B-60595	-	3/8" x 24"	B-60682	-	5/8" x 24"	B-60779	-			
1/4" x 4"	B-60604	B-60888	7/16" x 12"	B-60698	-	3/4" x 8"	B-60785	-			
1/4" x 6"	B-60610	B-60894	1/2" x 6"	B-60707	B-60931	3/4" x 12"	B-60791	-			
1/4" x 12"	B-60626	-	1/2" x 12"	B-60713	B-60947	3/4" x 24"	B-60800	-			
5/16" x 6"	B-60632	B-60903	1/2" x 24"	B-60729	-	7/8" x 12"	B-60816	-			



DUST EXTRACTION HEAD

- Eliminates the need for "Blow-Brush-Blow" method when installing anchors
- Reduces airborne silica dust and offers increased productivity during chemical anchor installation

SDS-MAX DUST EXTRACTION BITS

Diameter/Length	Usable Length	Cutters	Part # (1/Pk)
1/2" x 24"	15-3/4"	3	B-63828
9/16" x 24"	15-3/4"	3	B-63834
5/8" X 24"	15-3/4"	3	B-63840
3/4" X 24"	15-3/4"	3	B-63862
7/8" x 24"	15-3/4"	10	B-63884
1" x 24"	15-3/4"	10	B-63890
1-1/8" x 24"	15-3/4"	10	B-63909
1-3/8" x 24"	15-3/4"	10	B-63937

B-63943
Vacuum Attachment
Replacement Vacuum Attachment for Makita SDS-MAX Dust Extraction Drill Bits

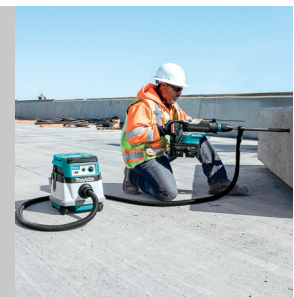

PRECISION CORDLESS CUTTING



XAG23ZU1 **NEW**
18V X2 LXT® (36V) Brushless 9" Angle Grinder, AWS™

- The BL™ Brushless Motor eliminates carbon brushes, enabling the BL™ Motor to run cooler and more efficiently for longer life; delivers 6,000 RPM
- Auto-start Wireless System (AWS™) utilizes Bluetooth® technology for wireless power-on/off communication between tool and dust extractor

DUST EXTRACTION ATTACHMENT



198509-5
9" Dust Extraction Cutting Guard

- Fully Featured Sawing Guard for Precision Cutting and Maximum Dust Extraction
- For use with Makita XAG13Z and XAG23Z



GA7011C
7" Angle Grinder

- Powerful 15.0 AMP motor delivers 6,000 RPM
- Constant speed control automatically applies additional power to the motor to maintain speed under load
- Soft start suppresses start-up reaction for smooth start-ups and longer gear life



GA7040S
7" Angle Grinder

- Powerful 15.0 AMP motor delivers 8,000 RPM
- Soft Start suppresses start-up reaction
- Rotatable back handle for increased comfort in various applications



XAG22ZU1 **NEW**
18V X2 LXT® (36V) Brushless 7" Angle Grinder, AWS™

- The BL™ Brushless Motor eliminates carbon brushes, enabling the BL™ Motor to run cooler and more efficiently for longer life; delivers 7,800 RPM
- Two 18V LXT® Lithium-Ion batteries deliver corded power without leaving the 18V LXT® battery platform (batteries not included)

DUST EXTRACTION ATTACHMENT



195386-6
7" - 9" Dust Extracting Surface Grinding Shroud

- 4-spring suspension system keeps shroud flush with surface during movement



XAG20Z
4-1/2" / 5" Paddle Switch Cut-Off/Angle Grinder, with Electric Brake, Tool Only

- Electric Brake stops the grinding or cut-off wheel in 2 seconds or less for maximum productivity
- Active Feedback-sensing Technology (AFT™) turns the motor off if rotation of the wheel is suddenly forced to stop



GA5042C
5" SJS™ II High-Power Angle Grinder

- Powerful 12.0 AMP motor delivers more output and variable (2,800 - 11,000) RPM
- SJS™ II Technology Reduces Vibration for User Comfort



9565CV
4-1/2" / 5" SJS™ Angle Grinder

- Powerful 13 AMP motor delivers more output and variable (2,800 - 10,500) RPM
- SJS™ mechanical clutch system helps prevent motor and gear damage
- Soft start suppresses start-up reaction for smooth start-ups and longer gear life

DUST EXTRACTION ATTACHMENTS



193794-5
4-1/2" - 5" Dust Extracting Cutting Guard



192618-2
4-1/2" - 5" Dust Extracting Cutting Guard



195236-5
4-1/2" - 5" Dust Extracting Surface Grinding Shroud



PC5010CX1 **NEW**
5" SJS™ II Concrete Planer with Dust Extraction Shroud and Diamond Cup Wheel

- Integrated dust extraction shroud is designed to capture dust during concrete surfacing applications
- Powerful 12.0 AMP motor delivers more output and (4,000 - 9,000) RPM
- SJS™ II provides a drive mechanism that is engineered to reduce vibration for increased comfort during extended use



PC5000C
5" Concrete Planer

- Electronic controller for operator convenience
- Powerful 10 AMP motor delivers more output and 10,500 RPM
- Constant Speed Control automatically applies additional power to the motor to maintain speed under load

ANTI-VIBRATION CUP WHEELS

Size	Rim	Part #
4-1/2"	Double Row	A-96198
4-1/2"	Turbo	A-96403
7"	Single Row	A-96207
7"	Double Row	A-96213
7"	12 Segment Turbo	A-96419
7"	24 Segment Turbo	A-96425

DIAMOND CUP WHEELS

Size	Description	Model	Part #
5"	Segmented Rim	PC5000C, PC001C	A-95009
5"	Continuous Rim		A-94998



HP2070F
3/4" Hammer Drill w/ L.E.D Light

- Dual purpose for "Hammering" or "Drilling"
- Powerful 8.2 AMP motor for heavy duty use
- Large trigger switch and 360° swivel side handle for added comfort



HP2010N
3/4" Hammer Drill

- Industrial metal gear housing for durability
- 2-speed gear change for ideal speed and power
- Powerful 6 AMP motor for the most demanding applications

CARBIDE TIPPED PERCUSSION DRILL BITS



Diameter/Length	Usable Length	Part #	Diameter/Length	Usable Length	Part #
1/8" x 3"	1-3/8"	B-68719	3/8" x 12"	10"	B-68828
5/32" x 6"	4"	B-68725	7/16" x 6"	4"	B-68834
3/16" x 3-1/2"	2-1/2"	B-68731	1/2" x 6"	4"	B-68840
3/16" x 6"	4"	B-68747	1/2" x 12"	10"	B-68856
7/32" x 6"	4"	B-68753	9/16" x 6"	4"	B-68862
1/4" x 4"	2-1/2"	B-68769	5/8" x 6"	4"	B-68878
1/4" x 6"	4"	B-68775	5/8" x 12"	10"	B-68884
1/4" x 12"	10"	B-68781	3/4" x 6"	4"	B-68890
5/16" x 6"	4"	B-68797	3/4" x 12"	10"	B-68909
5/16" x 12"	10"	B-68806	7/8" x 12"	10"	B-68915
3/8" x 6"	4"	B-68812			



BRUSHLESS X2
18V + 18V = 36V
MAXIMUM PERFORMANCE
NO CORDS NEEDED

NEW

XRH07PTUN LXT BRUSHLESS
18V X2 LXT® (36V) Brushless 1-9/16"
Advanced AVT® Rotary Hammer Kit, AFT®, AWS™

- Two 18V LXT® Lithium-Ion batteries deliver the power and run time for corded demands without leaving the 18V LXT® platform
- Powerful BL™ Brushless motor delivers 250-500 RPM, 1,450-2,900 BPM and 8.4 ft.lbs. of impact energy to handle the most demanding applications
- Auto-start Wireless System (AWS™) utilizes Bluetooth® technology for wireless power-on/off communication between tool and dust extractor



XRH08PTW NEW
18V X2 LXT® 36V Brushless 1-1/8" AVT®
Rotary Hammer Kit w/ HEPA Dust Extractor
accepts SDS-PLUS bits

- X2 LXT® technology delivers up to 140 1/2" x 2-3/8" holes per charge using two 18V LXT® 5.0Ah batteries
- Powerful BL™ Brushless motor delivers 0-980 RPM, 0-5,000 BPM and 2.3 ft.lbs. of impact energy to handle the most demanding applications



XRH10PTW NEW
18V X2 LXT® 36V Brushless 1-1/8" AVT®
Rotary Hammer Kit, AFT®, AWS™ Capable
accepts SDS-PLUS bits

- X2 LXT® technology delivers up to 140 1/2" x 2-3/8" holes per charge using two 18V LXT® 5.0Ah batteries
- OSHA Table 1 compliant on-board dust extractor includes a filter cleaning mechanism designed to help maintain optimum suction efficiency



XRH011TX
18V LXT® Brushless 1" Rotary Hammer Kit
accepts SDS-PLUS bits

- The built-on vacuum attachment captures concrete dust during drilling and is activated by the tool for operator convenience
- Vacuum powered by separate motor to maintain tool drilling performance, and provide a 2-second delay to help capture remaining concrete dust

DUST EXTRACTION ATTACHMENTS



195173-3
Dust Extraction Cup

- Use with XRH01, XRH08 and XRH10



XRH12TW
18V LXT® Brushless 11/16" AVT® Rotary
Hammer Kit w/ Dust Extractor
AWS™ Capable, accepts SDS-PLUS bits

- OSHA Table 1 compliant on-board dust extractor includes a filter cleaning mechanism designed to help maintain optimum suction efficiency
- Efficient HEPA filtration system captures 99.97% of particulates .3 microns and larger



XRH03T
18V LXT® 7/8" Rotary Hammer Kit
accepts SDS-PLUS bits

- Makita-built variable speed motor delivers 0-1,200 RPM and 0-4,000 BPM
- 3-mode operation for "rotation only", "hammering with rotation" or "hammering only" for multiple applications



XRH04T
18V LXT® 7/8" Rotary Hammer Kit
accepts SDS-PLUS bits

- Makita-built variable speed motor delivers 0-1,200 RPM and 0-4,000 BPM
- 3-mode operation for "Rotation Only", "Hammering with Rotation" or "Hammering Only" for multiple applications

DUST EXTRACTION ATTACHMENTS



193472-7
Dust Extraction Attachment,
SDS-Plus, Drilling

- Depth stop adjustment allows drilling up to 4" deep and bits up to 3/4"
- Telescoping spring loaded barrel provides job site durability
- Use with XRH01, XRH03, XRH04 and XRH06



XKH01T1J NEW
18V LXT® Brushless Cordless AVT® Power Scraper Kit
accepts SDS-PLUS bits

- Brushless motor delivers 0-3,200 BPM and 2.2 ft.lbs. of impact energy to handle the most demanding applications
- Anti-Vibration Technology is a vibration absorbing housing which moves independently of the hammer mechanism effectively isolating vibration



XRH06RB
18V LXT® Sub-Compact Brushless 11/16" Rotary Hammer Kit
accepts SDS-PLUS bits

- Brushless motor delivers 0-680 RPM, 0-4,800 BPM and .88 ft.lbs./1.2 Joules of impact energy for faster drilling
- Compact and Ergonomic design at only 10-3/4"

DUST EXTRACTION ATTACHMENTS



199245-6
Dust Extraction Cup Set

- Ideal for overhead drilling applications
- For use with Makita Rotary Hammer models RH01Z, RH02Z, XRH06Z and XRH12ZW

*Compliant under Option 2, Objective Data of the OSHA standard for Occupational Exposure to Respirable Crystalline Silica (rule 1926.1153) when dust extractor is operated with the tested tool model and operated under conditions tested by Makita®. To see the test procedures go to: makitatools.com/dustmanagement.

LXT BRUSHLESS XPT™ 5.0Ah BATTERY



BALE TOOL AVAILABLE
XPH07Z

XPH07TB
18V LXT® Brushless
1/2" Hammer Driver-Drill Kit

- BL™ Brushless Motor delivers 1,090 in.lbs. of Max Torque
- Efficient BL™ Brushless motor is electronically controlled to optimize battery energy use for up to 50% longer run time per charge

LXT BRUSHLESS XPT™ 5.0Ah BATTERY



BALE TOOL AVAILABLE
XDT14Z

XDT14T
18V LXT® Brushless
3-Speed Impact Driver Kit

- Quick-Shift Mode™ uses the brushless motor's electronic controls to find the best balance of speed and torque for each application
- Tightening Mode (T-mode) for faster tightening of self-drilling screws; helps prevent damage to the screw or workpiece

LXT BRUSHLESS 5.0Ah BATTERY



BALE TOOL AVAILABLE
XWT07Z

XWT07T
18V LXT® Brushless
3/4" Impact Wrench Kit

- BL™ Motor delivers 780 ft.lbs. of fastening torque and 1,250 ft.lbs. of breakaway torque
- 3-speed power selection switch (0-900/ 0-1,000/ 0-1,800 RPM & 0-1,800/ 0-2,000/ 0-2,200 IPM) provides precise fastening control

LXT BRUSHLESS 5.0Ah BATTERY



BALE TOOL AVAILABLE
XWT08Z

XWT08T
18V LXT® Brushless
1/2" Impact Wrench Kit

- BL™ Motor delivers 740 ft.lbs. of fastening torque and 1,180 ft.lbs. of breakaway torque
- 3-speed power selection switch (0-900/ 0-1,000/ 0-1,800 RPM & 0-1,800/ 0-2,000/ 0-2,200 IPM) provides precise fastening control

LXT 4.0Ah BATTERY



BALE TOOL AVAILABLE
XWT04Z

XWT04MB
18V LXT® 1/2" Impact Wrench Kit

- Makita-built motor delivers 325 ft.lbs. of Max Torque, with 1,600 RPM and 2,200 IPM for superior fastening power
- Shock absorbent handle protects battery housing for extra durability
- Rocker switch for forward/reverse operation

LXT BRUSHLESS XPT™ 5.0Ah BATTERY



BALE TOOL AVAILABLE
XRJ05Z

XRJ05T
18V LXT® Brushless Recipro Saw Kit

- Makita-built variable 2-speed brushless motor delivers 0-2,300 (Low) & 0-3,000 (High) strokes per minute and a 1-1/4" stroke length for faster cutting
- "Tool-less" blade change system allows for faster blade installation and removal for increased productivity

LXT BRUSHLESS 5.0Ah BATTERY

AUTOMATIC SPEED CHANGE™



BALE TOOL AVAILABLE
XSH06Z

XSH06T
18V X2 LXT® (36V) Brushless
7-1/4" Circular Saw Kit

- BL™ motor delivers 5,000 RPM for faster cutting and ripping
- Automatic Speed Change™ technology adjusts speed and torque during operation for optimum performance

LXT BRUSHLESS 5.0Ah BATTERY



BALE TOOL AVAILABLE
XSR01Z

XSR01PT
18V X2 LXT® (36V) Brushless
Rear Handle 7-1/4" Circular Saw

- Makita-built motor delivers 0-1,250 RPM, 0-5,000 BPM and 3.0 Joules of impact energy for fast drilling
- The BL™ Brushless Motor eliminates carbon brushes, enabling the BL™ Motor to run cooler and more efficiently for longer life

LXT 5.0Ah BATTERY



BALE TOOL AVAILABLE
XBU05Z

XBU05TS1
18V LXT® Blower Kit

- Makita-built variable 3-speed motor produces a maximum air velocity of 219 MPH
- Weighs only 4.1 lbs. with battery (battery not included) for reduced operator fatigue
- Compact and ergonomic design at only 20-3/8" long

LXT BRUSHLESS 5.0Ah BATTERY



BALE TOOL AVAILABLE
XBU02Z

XBU02PT
18V X2 (36V) LXT® Brushless Blower Kit

- Delivers up to 28 minutes of run time at mid-speed (15,800 RPM) using two 18V LXT® 5.0Ah batteries
- BL™ Brushless motor delivers up to 120 MPH air velocity and 473 CFM of air volume
- Sound pressure rating of 61 dB(A); measured per ANSI B 175.2 standard

MM4 4-STROKE ENGINE



PM7650H
75.6 cc MM4® 4-Stroke Engine Mist Blower

- L-shaped chemical tank lowers center of gravity for improved balance
- Single action switch to activate liquid chemical flow
- Liquid chemical in tank is automatically mixed by intake air flow for uniform solution concentration

LXT BRUSHLESS



XUC01X1
18V X2 LXT® Brushless
Power-Assisted Wheelbarrow

- Delivers up to 60 minutes of run time (distance equivalent to one mile) under load using one 18V LXT® 6.0Ah BL1860 battery (battery not included)

LXT BRUSHLESS



XUC01X2
18V X2 LXT® Brushless
Power-Assisted Flat Dolly

- Delivers up to 60 minutes of run time (distance equivalent to one mile) under load using one 18V LXT® 6.0Ah BL1860 battery (battery not included)

LXT X2 18V + 18V 36V



DML810
18V X2 LXT® Upright
L.E.D. Area Light

- Self-righting design keeps work light in upright position

LXT X2 18V + 18V 36V



DML809
18V X2 LXT®
Cordless/Corded Work Light

- 3-mode operation: delivers 10,000 lumens on High, 4,000 lumens on medium, and 2,000 lumens on Low

LXT



DML811
18V LXT®
Cordless/Corded Work Light

- 3-mode operation: delivers 3,000 lumens on High, 1,500 lumens on medium, and 750 lumens on Low

DRILLING / CHIPPING

	Model	Max. Size	Optimum Range	Max. Core Bit	Power	Impact Energy	RPM	BPM	Torque Control	Length	Weight	Chipping
ACCEPTS SDS-MAX BITS	AVT HR5212C	2"	3/4" - 1-9/16"	6-1/4"	15A	14 ft.lbs.	130 - 260	1,100 - 2,250	Yes	23-1/2"	26.2 lbs.	Yes
	AVT HR4510C	1-3/4"	3/4" - 1-3/8"	5"	13.5A	9.2 ft.lbs.	130 - 280	1,250 - 2,250	Yes	18"	19.6 lbs.	Yes
	AVT HR4013C	1-9/16"	5/8" - 1-1/4"	4-1/8"	11A	8.4 ft.lbs.	250 - 500	1,450 - 2,900	Yes	18-11/16"	15.1 lbs.	Yes
	AVT HR4002	1-9/16"	1/2" - 1"	4-1/8"	10A	4.6 ft.lbs.	2,500	680	Yes	18"	14.6 lbs.	Yes
	AVT XRH07PTU	1-9/16"	5/8" - 1-1/4"	4-1/8"	X2 18v	8.4 ft.lbs.	250 - 500	1,450 - 2,900	Yes	18-5/8"	16.8 lbs.	Yes
	AVT XRH07PTUN	1-9/16"	5/8" - 1-1/4"	4-1/8"	X2 18v	8.4 ft.lbs.	250 - 500	1,450 - 2,900	Yes	18-5/8"	16.8 lbs.	Yes
ACCEPTS SPLINE BITS	AVT HR5000	2"	5/8" - 1-3/8"	5-7/8"	11A	8.7 ft.lbs.	260	2,100	Yes	18-3/4"	21.8 lbs.	Yes
	AVT HR4041C	1-9/16"	1/2" - 1"	4-5/8"	12A	6.8 ft.lbs.	230 - 460	1,300 - 2,600	Yes	16-7/8"	14.8 lbs.	Yes
ACCEPTS SDS-PLUS BITS	AVT HR3210C	1-1/4"	1/2" - 7/8"	3-1/2"	8.2A	4.1 ft.lbs.	315 - 630	1,650 - 3,300	Yes	15-5/8"	11.4 lbs.	Yes
	AVT HR2811F	1-1/8"	1/4" - 5/8"	3-1/8"	7A	2.1 ft.lbs.	0 - 1,100	0 - 4,500	Yes	12-5/8"	7.7 lbs.	Yes
	AVT HR2651	1"	1/4" - 5/8"	3-1/8"	7A	1.6 ft.lbs.	0 - 1,200	0 - 4,600	Yes	16-7/16"	9.3 lbs.	Yes
	AVT HR2661	1"	1/4" - 5/8"	3-1/8"	8A	1.6 ft.lbs.	0 - 1,100	0 - 4,500	Yes	18-7/8"	9.7 lbs.	Yes
	AVT HR2641	1"	1/4" - 5/8"	3-1/8"	8A	2.1 ft.lbs.	0 - 1,100	0 - 4,500	Yes	16-5/8"	7.1 lbs.	Yes
	AVT HR2475	1"	3/16" - 1/2"	3-1/8"	7A	2 ft.lbs.	0 - 1,100	0 - 4,500	Yes	16-7/8"	6.6 lbs.	Yes
	AVT HR2631F	1"	3/16" - 1/2"	2-11/16"	7A	2.1 ft.lbs.	0 - 1,200	0 - 4,600	Yes	15-1/8"	6.6 lbs.	Yes
	AVT HR1840	11/16"	5/32" - 3/8"	1-3/8"	4.5A	1.03 ft.lbs.	0 - 2,100	0 - 4,800	Yes	11-1/4"	4.3 lbs.	Yes
	AVT XRH10PTW	1-1/8"	1/4" - 5/8"	2-1/8"	X2 18v	2.3 ft.lbs.	0 - 980	0 - 5,000	AFT	14-3/4"	11 lbs.	Yes
	AVT XRH08PTW	1-1/8"	3/16" - 5/8"	2-1/8"	X2 18v	2.3 ft.lbs.	0 - 980	0 - 5,000	Yes	14-3/4"	10.8 lbs.	Yes
	AVT XRH01T	1"	3/16" - 1/2"	—	18v	1.7 ft.lbs.	0 - 950	0 - 4,700	Yes	14-5/8"	7.2 lbs.	Yes
	AVT XRH04T	7/8"	5/32" - 1/2"	—	18v	1.4 ft.lbs.	0 - 1,100	0 - 4,000	Yes	16-3/8"	7.7 lbs.	Yes
	AVT XRH06RB	11/16"	5/32" - 3/8"	—	18V	.88 ft.lbs.	0 - 680	0 - 4,800	No	10-3/4"	4.6 lbs.	No
	AVT XRH12TW	11/16"	5/32" - 3/8"	—	18V	1.2 ft.lbs.	0 - 1,350	0 - 5,000	Yes	11-7/8"	7.5 lbs.	Yes

ELECTRONIC CONTROLLER

ON CORDED MODELS THAT END WITH "C"

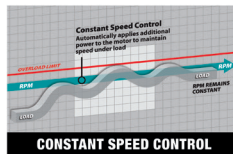

Automatically applies additional power to the motor to maintain speed under load

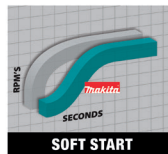

Suppresses start up reaction for more control and better accuracy





Control dial that enables user to match speed to application















Notifies user of switch/cord failure and imminent brush replacement









DRILLING

	Model	Max. Size	Optimum Range	Max. Core Bit	Power	Impact Energy	RPM	BPM	Torque Control	Length	Weight	Chipping
HAMMER DRILLS	 HP2070F	3/4"	5/32" - 7/16"	—	8.2A	—	Low: 0-1,200 High: 0-2,900	Low: 0-24,000 High: 0-58,000	No	14-1/4"	5.6 lbs.	No
	 HP2050F/ HP2050	3/4"	5/32" - 7/16"	—	6.6A	—	Low: 0-1,200 High: 0-2,900	Low: 0-24,000 High: 0-58,000	No	14-1/4"	5.6 lbs.	No
	 LXT BRUSHLESS XPH07T	1/2"	5/32" - 7/16"	—	18V	—	Low: 0-550 High: 0-2,100	Low: 0-8,250 High: 0-31,500	No	8-1/8"	5.9 lbs.	No

DEMOLITION

	Model	Size	Bit Type	Power	Impact Energy	BPM	Noise Level (dB)	Vibration (m/s ²)	Length	Weight
HEAVY	 AVT HM1812	70 lb.	1-1/8" Hex	15A	53.9 ft.lbs.	870	106	6.5	33-1/4"	69.1 lbs.
	 AVT HM1810	70 lb.	1-1/8" Hex	15A	46.5 ft.lbs.	1,100	107	9	32-1/2"	71.3 lbs.
	 AVT HM1317C	42 lb.	1-1/8" Hex	14A	25.7 ft.lbs.	730 - 1,450	104	7	32-1/2"	41.9 lbs.
	 AVT HM1307C	35 lb.	1-1/8" Hex	14A	25.7 ft.lbs.	730 - 1,450	104	12	32-1/2"	38.2 lbs.
MEDIUM	 AVT HM1214C	27 lb.	SDS-MAX	14A	19 ft.lbs.	950 - 1,900	102	8	27-1/2"	27.1 lbs.
	 AVT HM1213C	23 lb.	SDS-MAX	14A	18.8 ft.lbs.	950 - 1,900	95	7	22-3/4"	23.8 lbs.
	 AVT HM1211B	20 lb.	3/4" Hex - 21/32" Round	10A	10.5 ft.lbs.	2,000	102	14	19-5/16"	20.7 lbs.
	 AVT HM1111C	17 lb.	SDS-MAX	14A	12.7 ft.lbs.	1,100 - 2,650	99	8	20-3/4"	17.7 lbs.
LIGHT	 AVT HM0810B	13 lb.	3/4" Hex - 21/32" Round	8.3A	5.6 ft.lbs.	2,900	99	8	16-5/8"	13.4 lbs.
	 AVT HM0871C	12 lb.	SDS-MAX	10A	8.6 ft.lbs.	1,100 - 2,650	98	8	18-3/8"	12.3 lbs.
SCRAPE	 Makita HK1810	—	Makita® Small	4.5A	2.9 ft.lbs.	0 - 3,200	99	13.5	12-3/8"	7.1 lbs.
	 AVT XKH01TJ	—	SDS-PLUS	18V	2.2 ft.lbs.	0 - 3,200	83	4.5	14-1/2"	7.9 lbs.

CUTTING / TUCK POINTING

	Model	Size	Max Cutting Depth	Power	RPM	Fuel Capacity	Five Stage Filter	Length	Weight
	 MMT EK8100	16"	5-3/4"	5.6 HP	3,820	37 oz.	Yes	32-3/4"	23.3 lbs.
	 MM4 EK7651H	14"	4-13/16"	4.1 HP	4,300	37 oz.	Yes	30-3/4"	28.3 lbs.
	 MMT EK7301	14"	4-13/16"	5.1 HP	4,300	37 oz.	Yes	30-1/4"	22 lbs.
	 MM4 EK6101	14"	5-1/8"	4.4 HP	4,400	23.6 oz.	No	29-1/2"	19.6 lbs.
	 X2 XEC01	9"	3-1/2"	36V	6,600	—	—	21-3/4"	13.9 lbs.
	 SJS 4114	14"	5"	15A	3,800	—	—	26-1/2"	23.8 lbs.
	 4101H	5"	1-5/8"	7.9A	13,800	—	—	9-1/4"	6.5 lbs.
	 4100KB	5"	1-9/16"	13A	12,200	—	—	9-1/8"	6.6 lbs.
	 SJS II GA5040X1	5"	1"	10A/12A	11,000 / 2,800 - 11,000	—	—	11-7/8"	5.4 lbs.



Makita takes another step toward a truly cordless job site with Auto-Start Wireless System. AWS™ uses Bluetooth® technology for wireless power-on and power-off communication between the equipped tool and dust extractor. AWS™ is intelligent communication that eliminates cords and excessive noise since the dust extractor runs only when trigger-activated by an AWS™ tool. When the trigger is released, the dust extractor powers-down. The Makita AWS™ dust extractor (XCV08Z) is powered by two 18V LXT® batteries for maximum performance, and users benefit with an expanding AWS™ system that includes cordless tools for concrete, metal and woodworking.

USES TWO
18V LXT
BATTERIES



LXT BATTERY **BRUSHLESS** **AWS** CAPABLE

XCV18PTX NEW
18V X2 (36V) LXT® Brushless
1.6 Gal. HEPA Filter Backpack
Dust Extractor Kit, AWS™ Capable

- Filter cleaning mechanism designed to help maintain optimum suction efficiency
- Powerful BL™ Brushless Motor generates 64 CFM of suction power and 44" of water lift
- Up to 62 minutes of continuous operation on normal setting and 33 minutes on high setting using two 18V LXT® 5.0Ah batteries BL1850B (batteries not included)
- Efficient two stage HEPA filter captures 99.97% of particulates .3 microns and larger extending the life of the main filter

USES TWO
18V LXT
BATTERIES



LXT BATTERY **BRUSHLESS** **AWS** CAPABLE

XCV10PTX
18V X2 LXT® (36V) Brushless Cordless
1/2 Gallon HEPA Filter Backpack Dry
Dust Extractor Kit, AWS™ Capable

- Powerful BL™ Brushless Motor generates 64 CFM of suction power and 44" of water lift
- Up to 62 minutes of continuous operation on normal setting and 33 minutes on high setting using two 18V LXT® 5.0Ah batteries BL1850B
- Efficient two stage HEPA filter captures 99.97% of particulates .3 microns and larger extending the life of the main filter



CONVENIENCE
AWS™ for wireless power-on/off communication with dust extractor

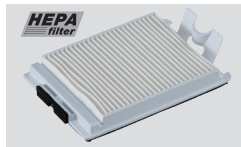

EFFICIENCY
Two stage HEPA filtration system captures 99.97% of particulates .3 microns and larger

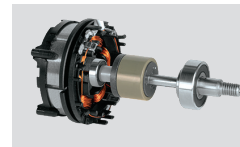

POWER
Powerful BL™ Brushless Motor generates 64 CFM of suction power and 44" of water lift

HYBRID
CORDLESS OR
CORDED



LXT BATTERY **X2** 18V + EST **36V**

XCV13Z
18V X2 LXT® (36V) Cordless/
Corded 4 Gallon HEPA Filter Dry Dust
Extractor/Vacuum, Tool Only

- Powerful Makita-built motor delivers 127 CFM and 96" water lift of suction using corded power
- Powerful Makita-built motor delivers 74 CFM and 36" water lift of suction using two 18V LXT® Lithium-Ion batteries (batteries not included)
- Efficient three stage HEPA filtration system captures 99.97% of particulates .3 microns and larger extending the life of the main filter

USES TWO
18V LXT
BATTERIES



LXT BATTERY **BRUSHLESS** **AWS** CAPABLE

XCV16ZX
18V X2 LXT® (36V) Brushless
Cordless 4 Gallon HEPA Filter Dry
Dust Extractor, AWS™, Tool Only

- Powerful BL™ Brushless motor delivers 74 CFM and 39" water lift of suction using two 18V LXT® Lithium-Ion batteries (batteries not included)
- Efficient three stage HEPA filtration system captures 99.97% of particulates .3 microns and larger
- Filter cleaning system is designed to maintain optimal suction efficiency and longer filter life

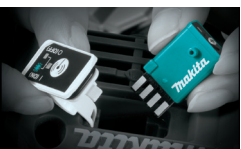

PRODUCTIVITY
AWS™ for wireless power-on/off communication with dust extractor (XCV16ZX only)

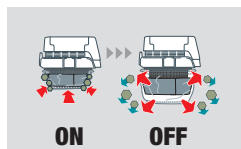

FILTER CLEANING
Filter cleaning system is designed to maintain optimal suction efficiency



EFFICIENCY
Efficient three stage HEPA filtration system captures 99.97% of particulates .3 microns and larger

NEW

POWERFUL WET/DRY DUST MANAGEMENT SOLUTION

VC4210L

11 Gallon Wet/Dry HEPA Filter Dust Extractor/Vacuum

Air Flow Rate	148 CFM
Static Water Lift	92"
Tank Size	11 gal.
Filter Cleaning	Yes
Variable Speed	Yes
Filtration System	3-Stage HEPA Filtration
Power Cord	24.6 ft.



Motor chamber constructed of quality sound-absorbing materials resulting in a quiet operating sound level of 60 dB(A)

Powerful 12 AMP motor generates 148 CFM of suction power and 92" of water lift



Secure interlocking case on top of the unit





On-board tool-activated power outlet

Large, wide-set rear wheels and steel casters provide increased stability and mobility on the job-site



ALSO AVAILABLE

	Part #	Description
	W107418351	Main Flat Filter, VC4210
	W107418353	Fleece Filter Bag, 5/pk, VC4210
	W107418355	Plastic Disposal Bag, 5/pk, VC4210
	W107418349	6 Pc. Floor Cleaning Set
	P-72964	12" Concrete Slurry Floor Nozzle
	W107414008	Vacuum Hose Y-Adapter
	WUT02U	Auto-Start Wireless Universal Adapter
	197212-5	Interlocking Case, Large



LXT BRUSHLESS

XCV11T / XCV11Z **NEW**

18V LXT® Brushless 2 Gallon HEPA Filter Portable Wet/Dry Dust Extractor/Vacuum

- Powerful BL™ Brushless motor delivers 57 CFM and 27" water lift of suction using an 18V LXT® Lithium-Ion battery (battery not included)
- Efficient HEPA filter captures 99.97% of particulates .3 microns and larger
- Up to 60 minutes of continuous run time using an 18V LXT® Lithium-Ion 5.0Ah battery BL1850B (battery not included)
- L.E.D. battery indicator shows charge level for 18V LXT® Lithium-Ion battery
- Compact and portable design with shoulder strap; weighs only 10.1 lbs. with 18V LXT® battery (battery and shoulder strap not included)
- Battery compartment keeps the battery protected from harmful debris on the jobsite

ALSO AVAILABLE

 **195548-6**
Cuff Joint Adapter, 38mm to 22mm

 **424379-9**
Tool Cuff Adapter, 24mm for 1" hose

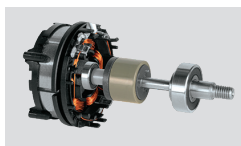

PERFORMANCE
Powerful Brushless motor delivers 57 CFM using a 18V LXT® Lithium-Ion battery









DUST MANAGEMENT
Two stage HEPA filtration system captures 99.97% of particulates .3 microns and larger



CONVENIENCE
On-board hose and nozzle storage allow for easy and convenient transport

GET **OSHA**  **HELPING YOU MANAGE CONCRETE DUST AND OSHA COMPLIANCE**

LEARN MORE
[MAKITATOOLS.COM/DUSTMANAGEMENT](https://www.makitatools.com/dustmanagement)

APPLICATION	APPLICABLE TOOLS	DUST ATTACHMENT	HOSE & ADAPTER	DUST EXTRACTOR	OSHA 29 CFR 1926.1153 COMPLIANT
DRILLING / CHIPPING / DEMOLITION	XRH01, XRH03, XRH04, XRH05, HR2641, HR2475, HR2811F	 193472-7 Dust Extraction Attachment			<p>YES</p> <p>Option 1, Under Table 1 of Specified Exposure Control Methods*</p>
	XRH01, XRH08, XRH10, HR2641	 195173-3 Dust Extraction Cup			
	HR4002, HR4510C	 196074-8 Dust Extraction Attachment		W107417866 	
	XRH07PTUN, XRH07PTU, HR4013C	 196537-4 Dust Extraction Attachment		W107418678 	
	HR5212C	 196858-4 Dust Extraction Attachment, Demolition		Both included with VC4210L	
	HM0870C, HM0871C, HM1111C, HR4002C, HR4510C, HR4041C	 196571-4 Dust Extraction Attachment, Demolition			
	HM1203C, HM1213C, HM1214C, HR5212C	 197172-1 Dust Extraction Attachment, 1-1/8" Hex Shank, Demolition		W107417866 	
CUTTING/TUCK-POINTING	9557 Series, 956 Series, GA502 Series	 196846-1 5" Dust Extraction Tuck Point Guard		W107418688 	<p>YES</p> <p>Option 1, Under Table 1 of Specified Exposure Control Methods</p>
	SJSII: GA5042C, GA4542C	 196845-3 5" Dust Extraction Tuck Point Guard		Both included with VC4210L	
	9557 Series, 956 Series, GA502 Series	 193794-5 5" Dust Extraction Cutting Guard			
	9557 Series, 956 Series, GA502 Series	 192618-2 5" Dust Extraction Cutting Guard		W107417866  W107418678  Both included with VC4210L	
GRINDING/SURFACING	9557 Series, 956 Series, GA502 Series, XAG04, XAG09, XAG11	 195236-5 4-1/2" / 5" Dust Extraction Surface Grinding Shroud		W107417866 	<p>YES</p> <p>Option 1, Under Table 1 of Specified Exposure Control Methods</p>
	PC5000C, PC5001C, PC5010CX1	 Integrated		W107418688 	
	GA7011C, GA7040S	 195386-6 7" Dust Extraction Surface Grinding Shroud		Both included with VC4210L	
DRYWALL CUTTING	XDS01	 Integrated		W107417866 	<p>N/A</p>
	XOC01, 3706	 193449-2 Dust Extraction Cut-Out Base		W107418678  Both included with VC4210L	

*Additionally HEPA filtered vacuum is required when cleaning holes.

**Compliant under Option 2, Objective Data of the OSHA standard for Occupational Exposure to Respirable Crystalline Silica (rule 1926.1153) when dust extractor is operated with the tested tool model and operated under conditions tested by Makita®. To see the test procedures go to [makitatools.com/dustmanagement](https://www.makitatools.com/dustmanagement).